



 Made in Belgium

AUDIOFOCUS

FF

When music meets science and technology

SL Series

User Manual

(2012 v1.0)

AudioFocus© a department of Community Europe s.a.
29, Rue Rempart de la Tour
5590 Ciney, B-5590 Belgium

www.audiofocus.eu

Head office : +32 83 21 80 54
Export department : +32 492 73 37 88
Fax : +32 83 21 80 57
sales@audiofocus.eu

Introduction :

Thank you for purchasing AudioFocus©. That product is designed and made in Belgium with the highest quality control and reliability. We hope you'll be fully satisfied by this device.

Slight serial has been designed for small to middle fixed or touring applications. Our main philosophy is that each model is available in active or passive version, and gives the possibility to be upgraded from Passive to Active version. This manual is made for both versions and is divided in three subsections: active, passive, and a third section for SLSuba-flex.

Don't hesitate to contact us in case of questions (sales@audiofocus.eu) or visit our website (www.audiofocus.eu).

⚠ Before starting the system, the user must read the safety instructions present at the end of this manual.

1. Active version (SL108a, SL112a, SL115a, SLSub15a, SLSub18a):

These models receive two ways *Powersoft* digital high efficiency amplifiers. These "green" energy amplifiers includes 4 presets for most of the applications we can meet on field.

Here's a description of the rear panel of Subs and Tops units:

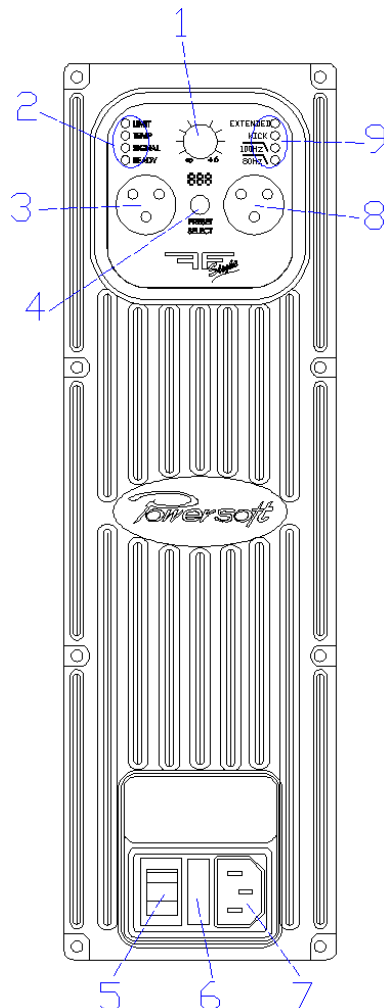

1. volume control from $-\infty$ to +6dBu.
2. diagnosis and status Leds.
3. balanced input XLR connector (female, 2+, 3-, 1GND).
4. preset selection switch.
5. main voltage switch.
6. fuse (T3.15A/240V). A spare fuse is present.
7. main voltage connector (IEC 240V).
8. balanced output XLR connector (male, 2+, 3-, 1GND).
This connector is parallel wired with the input (3) to link some cabinets together.
9. preset status leds.



1. The main voltage must be ALWAYS earthed to protect user in case of current losses or bad insulation.
2. ALWAYS replace the fuse with the same type and value (T3.15A/240V).
3. Make sure that the power switch is set to "OFF" before you connect the devices
4. A good cable improves the sound quality. Input cables should be as short as possible.
5. If long cable are necessary, you should use balanced cables.

Diagnosis and status Leds:

- Limit:** ON when output signal is @-3dBspl of the peak.
- Temp:** ON when working temperature is too high. The electronics get in protection.
- Signal:** ON when a signal is detected at the input of the cabinet.
- Ready:** ON after a few seconds, the system is ready for use.



Preset explanations:

User has the choice between 4 built-in presets to make the system plug and play. The preset select switch (4) permits to the user to choose the best preset for his application.

Top units (SL108a, SL112a, SL115a) :



- Full range :** flat response when the top unit is used alone on a stand.
- Extended :** a correction is applied on the LF transducer to extend the low frequency reproduction when the top unit is used alone (without sub).
- HPF :** use that preset if the top unit is coupled to a subwoofer. The top only deliver frequencies from 120Hz to 20kHz.
- Monitor :** the cabinet deliver a flat signal when placed on the floor. That preset is made for wedge applications.

Sub units (SLSub15a, SLSub18a) :

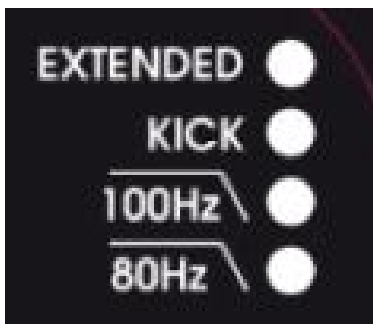

- Extended :** for subwoofer applications with lower cutoff frequency.
- Kick :** for bass application with a +3dBspl correction around 70-80Hz.
- 100Hz :** low pass cutoff frequency is 100Hz, 24dB/octave.
- 80Hz :** low pass cutoff frequency is 80Hz, 24dB/octave.

Remarks :

1. depending of the Sub/Top ratio, levels of each cabinet must be adjusted to reach the optimal sound result of the setup.
2. always use HPF preset for Top units when coupled to a subwoofer.
3. spl curves are available on request.

Examples of configurations:

In these examples you can consider all SL and SLSub models.

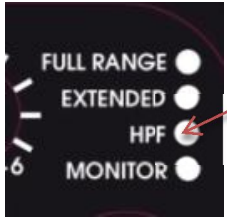

Always use HPF preset for Top units when coupled to a subwoofer.

Full stereo configuration

Stereo Top + mono Sub configuration

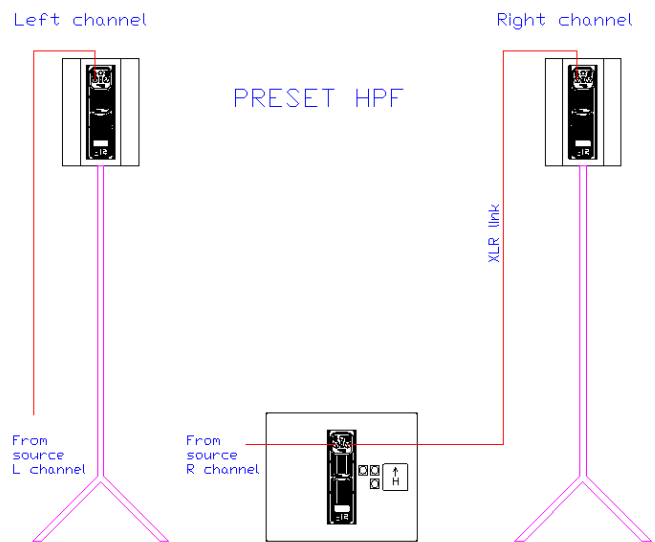
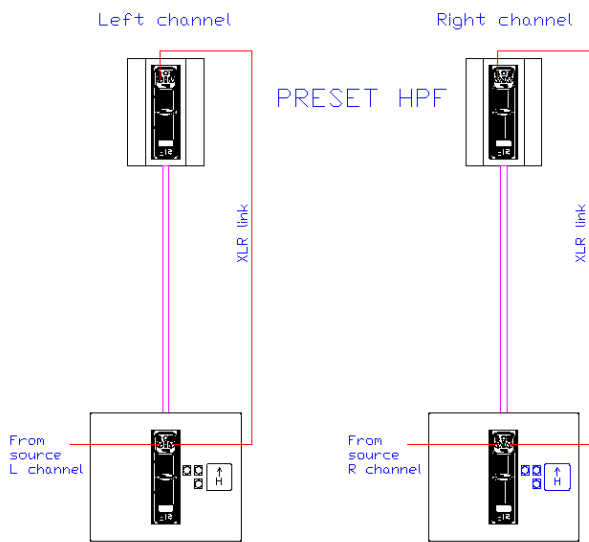

Stereo configuration



2. Passive version (SL108, SL112, SL115, SLSub15, SLSub18):

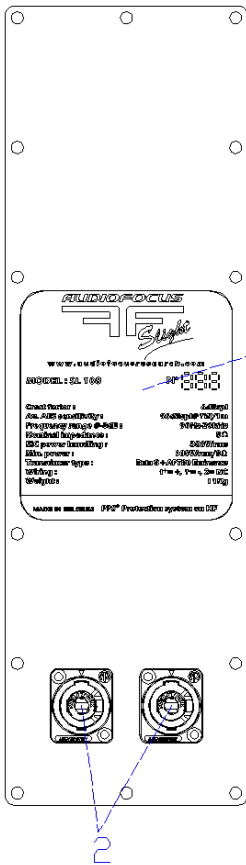

1 : rear serigraphic.

2 : Neutrik Speakon input/output connectors

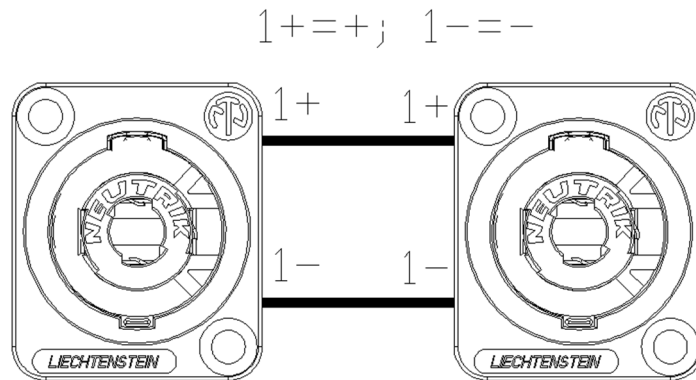

⚠ When linking identical speakers together (in parallel), the resulting impedance is divided by the quantity of speakers. The user must ALWAYS take care about this resulting impedance, and the minimum impedance allowed by the amplifier

8 ohms cabinet

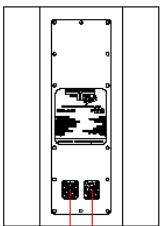

8 ohms cabinet

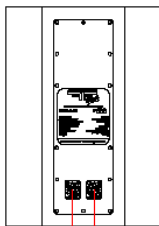

8 ohms cabinet

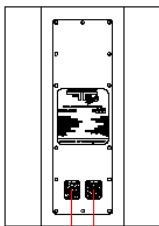

8 ohms cabinet

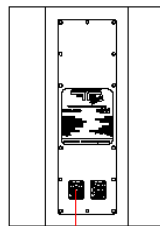

2 ohms cabinet

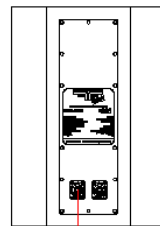

Examples of configurations:

Top units alone:

Top units alone with ADSP26 processor (optional)

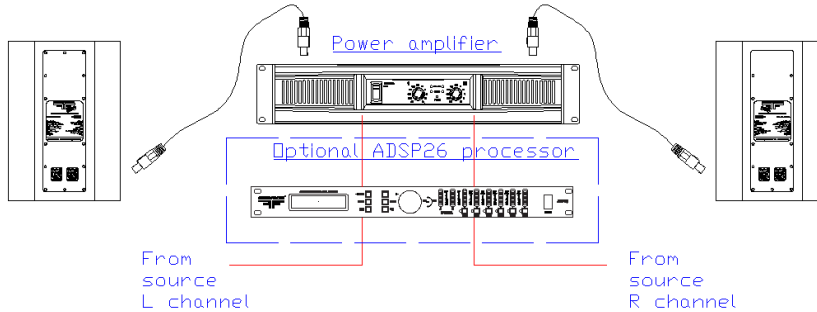

Top + Sub configuration:

In that case, one amplifier is used for the Top units and another one for the Sub units. Filtering between Top and Sub will be made by an ADSP26 AudioFocus© processor or any active Xover. The best way to achieve optimal audio result is to use ADSP26 AudioFocus© processor that includes the needed presets for your configuration.

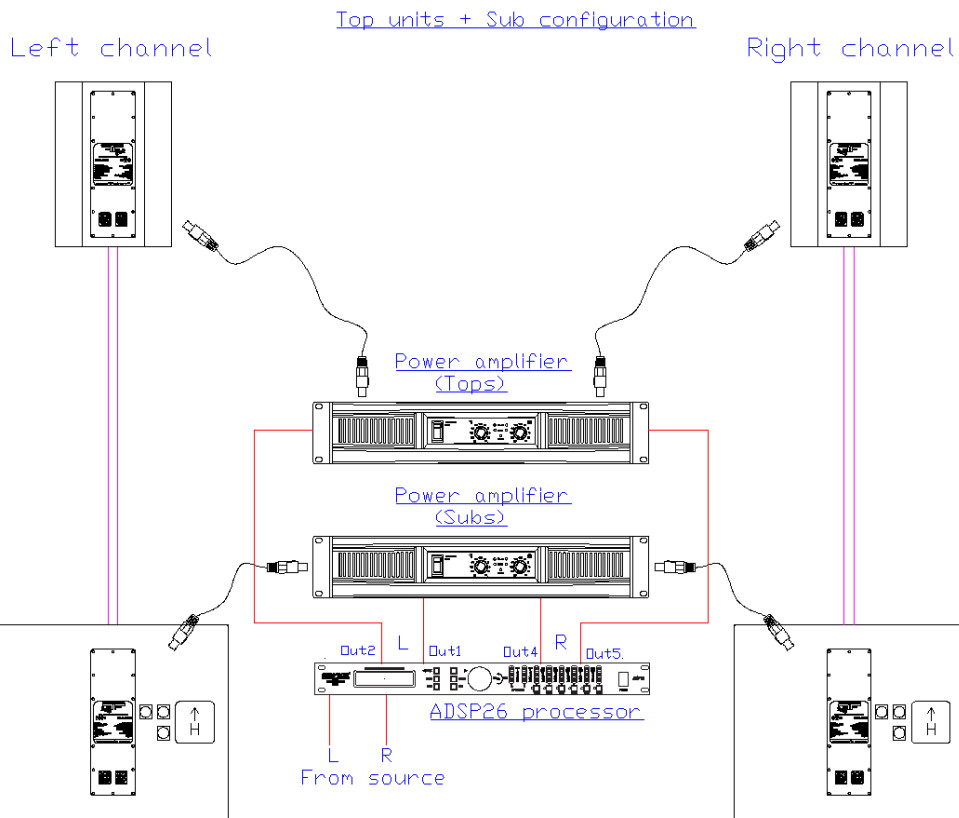

- ADSP26 processor is available with integrated presets for all our range. These presets can be recorded in the ADSP26 on demand. If not, our technical staff can send these by email.
- Compressor/limiter functions are integrated in ADSP26. Due to the fact that user can use several kind of amplifiers, we cannot calibrate ADSP26's limiter. The user must do it by himself taking care of the power handling of AudioFocus's cabinet, and the amplifiers' power.

3. Active Sub with auxiliary power outputs (SLSub15a-Flex, SLSub18a-Flex)

The best way to have a compact "plug and play" system is SLSuba -Flex. These has exactly the same features than the SLSuba, except that the amplifier module is a double one. So, SLSuba-Flex includes auxiliary power outputs for Top units.

To ensure a good Top/Subwoofer ratio, SLSuba-Flex has 4 presets. That permits coupling SLSuba-Flex with high, middle and low sensitivity Top units.

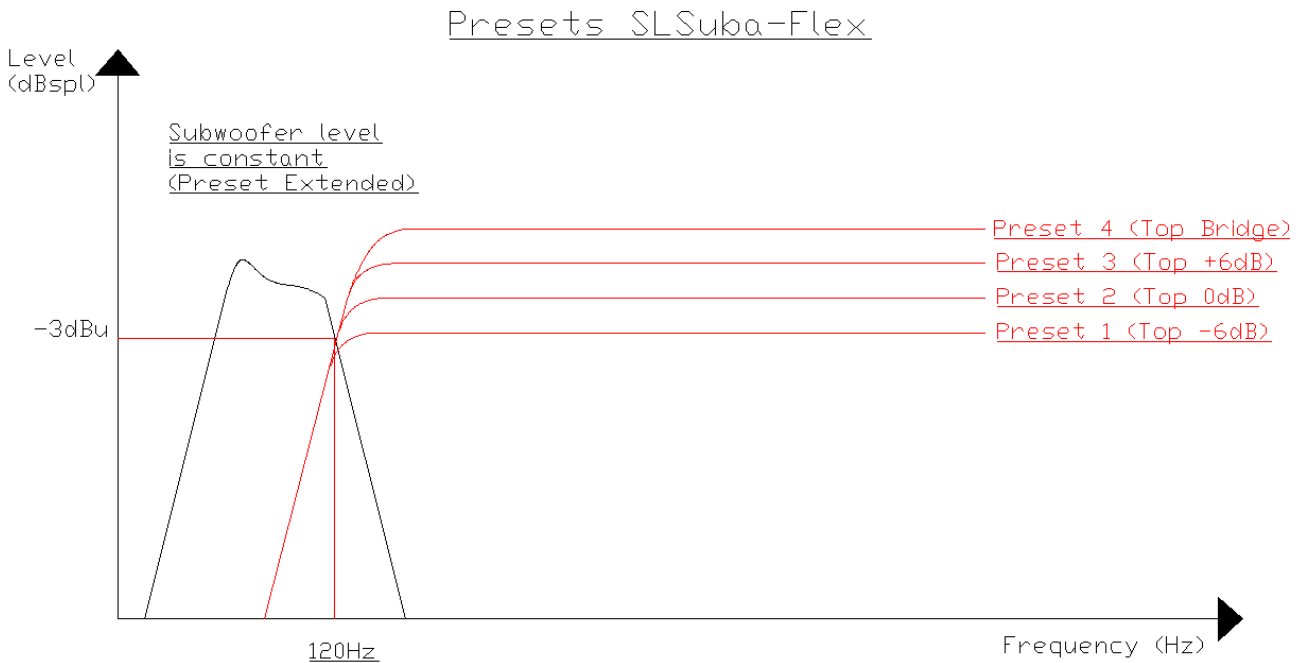

Rear connection description:

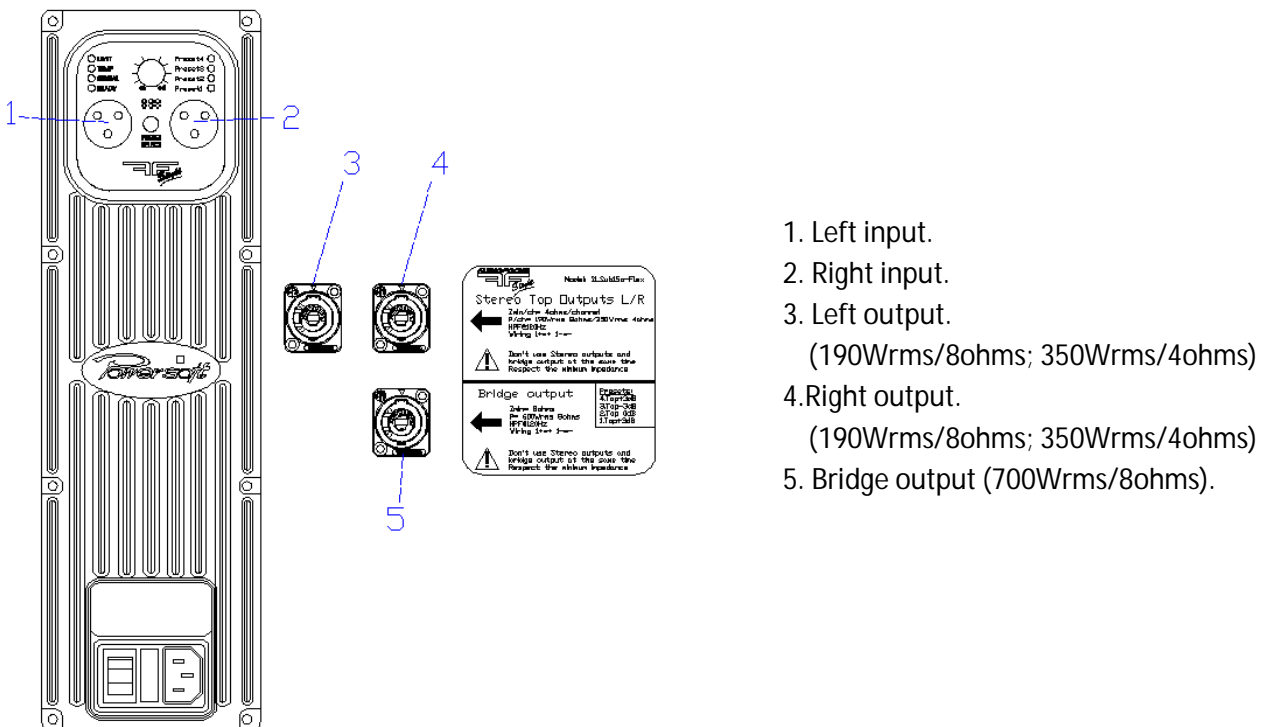

Examples of configurations:

Stereo Top + mono sub configuration:

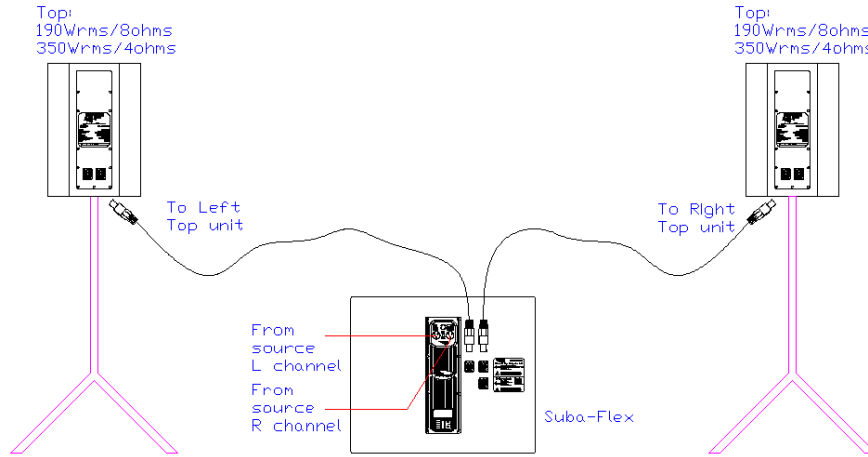

Stereo Top + stereo sub configuration:

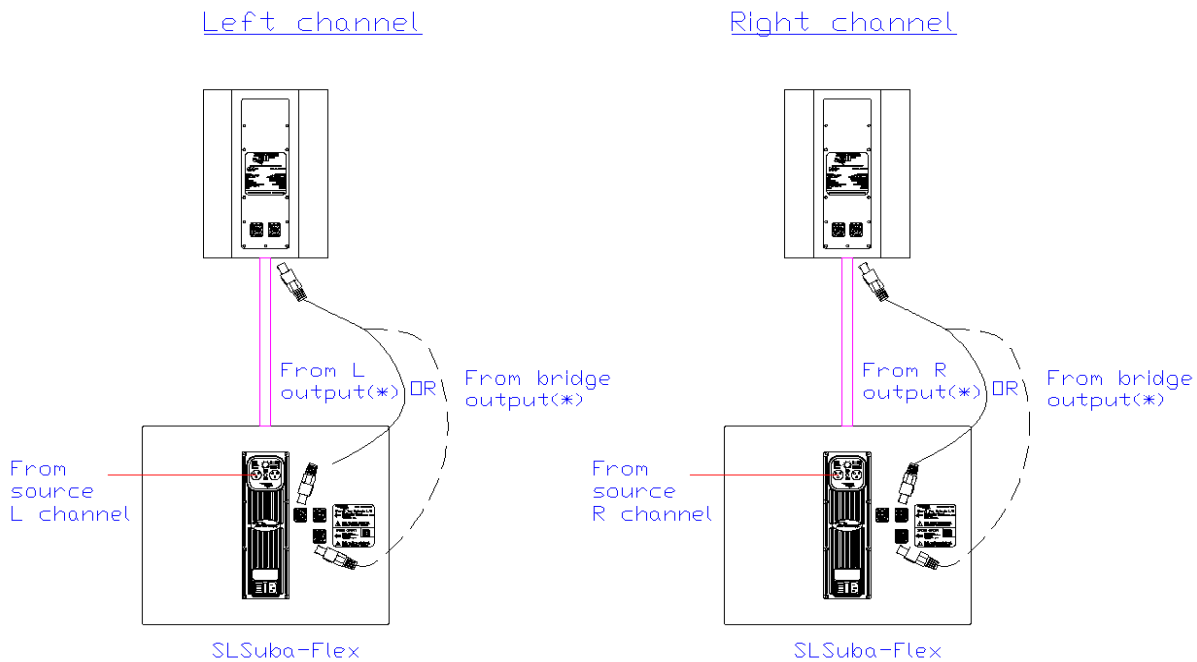

(*) From L&R outputs: 190rms/8ohms, 350Wrms/4ohms
From bridge output: 600Wrms/8ohms



- Never use stereo outputs and bridge output at the same time.
- Always respect minimum impedance (4ohms for stereo outputs, 8ohms for the bridge output).
- Coupling with other SLSuba (normal active version) are possible. In that case, user must configure SLSuba in Extended preset.
- Always consider the power capabilities of the top units wired to the SLSuba-Flex subwoofer.

Multi diffusion high quality configurations:

Auxiliary power outputs can go down to 4ohms (stereo outputs). So, SLSub15a-Flex and SLSub18a-Flex can be used as managing system for fixed installations.

Fixed installation: SL108 amplified by SLSuba-Flex

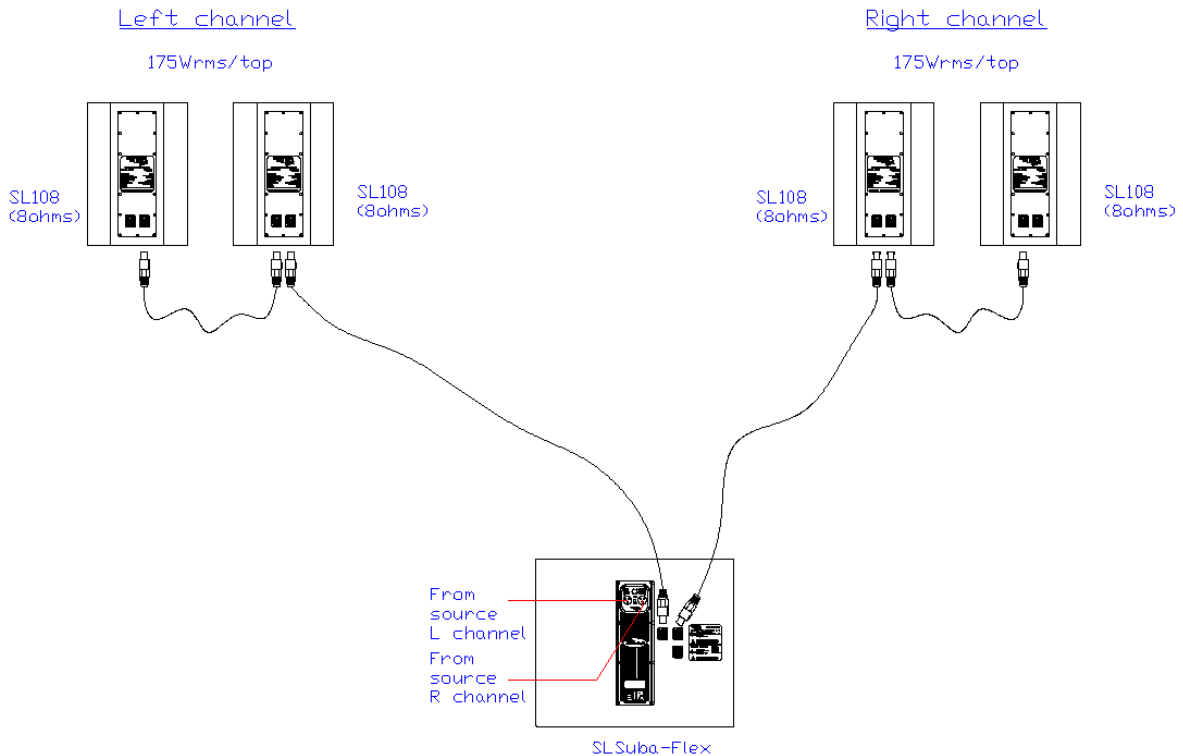

Fixed installation: FIX5.1 amplified by SLSuba-Flex

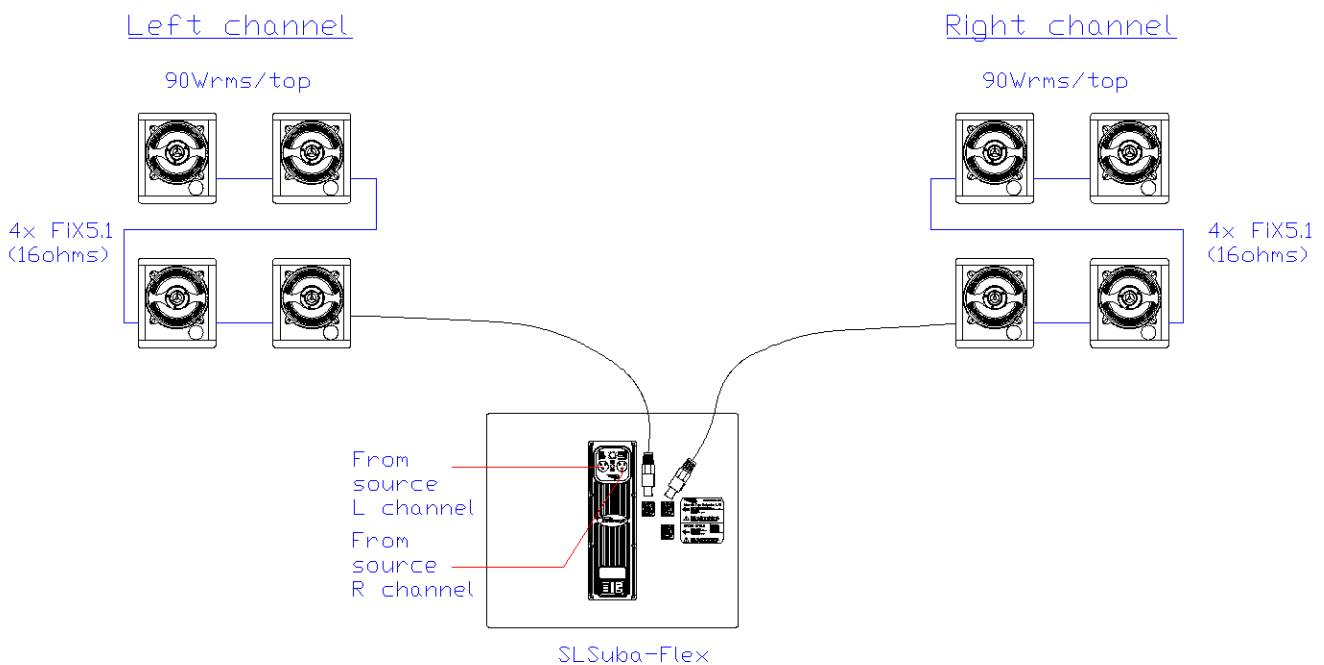

Accessories (not included) (sold separately):

This section describes different solutions for fixing system to truss or walls.

⚠ The user should ALWAYS use safety ropes to secure the system. That safety rope can be fixed on an eye bolt screwed in one of the M6 steel inserts.

Truss stand black (ref 35325) and silver (ref 35147):
Adjustable length and tiltable (3 positions)

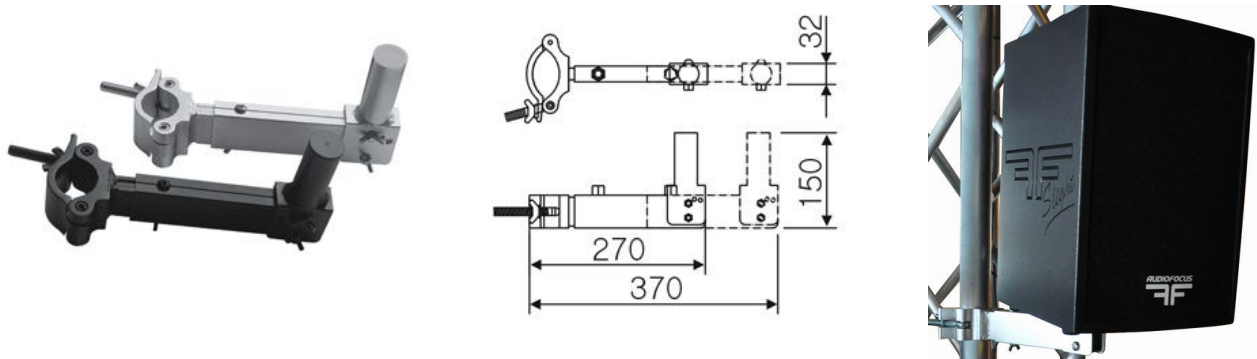

Wall mounting bracket (ref 17507):
It allows angle adjustment to reach the best cabinet TILT orientation.



M6 eye bolt (ref 16434) and rope/chain:

Each cabinet integrates M6 steel inserts to screw M6 eye bolt. With rope or chain, the user can place and adjust the cabinet (horizontally or vertically).

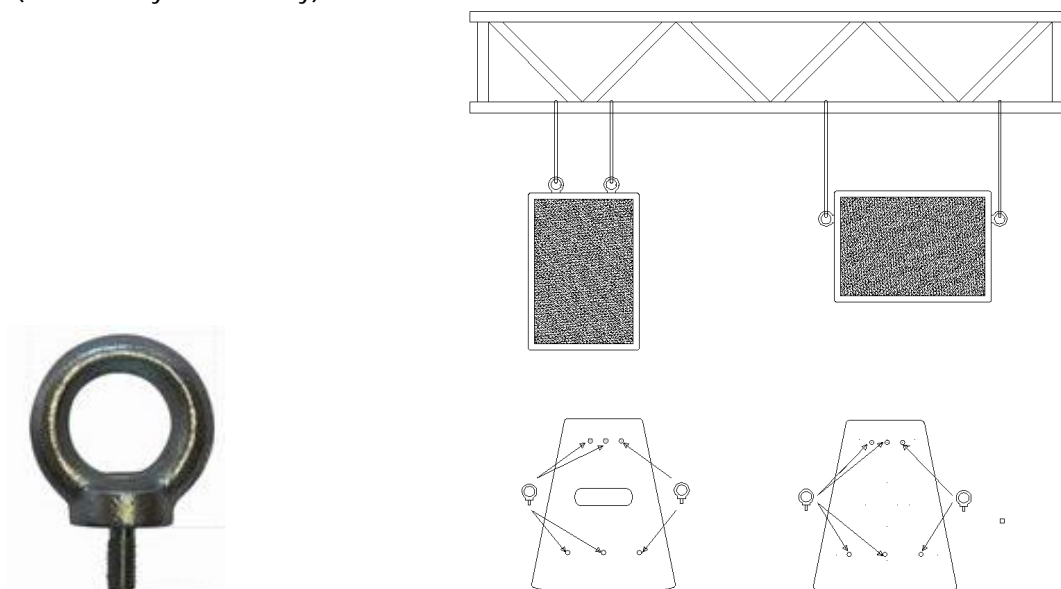

Bracket (fixed installations):

SL108(a) and SL112(a) have their own bracket for horizontal and vertical mounting.

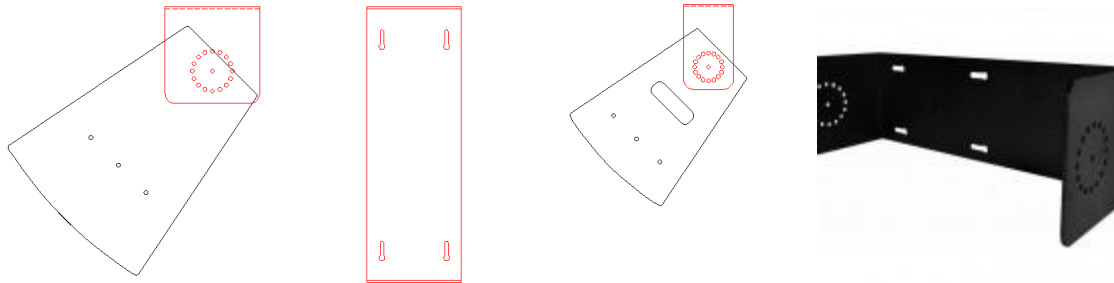

Six DIN7991 M6x25 screws are included with the bracket. Mechanical assembly will be made like that:

3x Din7991 M6x25 screws per side

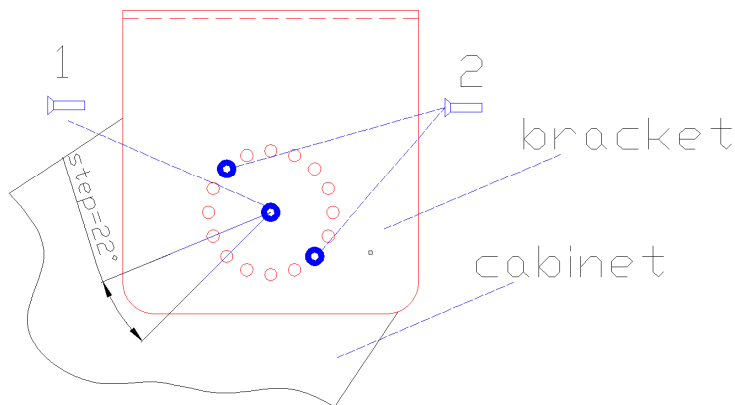

1. The first screw (noted 1) will be placed to make centering of the cabinet on the bracket. That screw must be placed on each side. Dont' tight these screws at 100%.
2. When the right angle is found (step of 22°), user must place place the two other screws (noted 2) on each side to fix definitively the cabinet's position.
3. Finish fixing by thigting all the screws.

Accessories:

AudioFocus© proposes a full range of accessories to setup the audio systems in best conditions. We invite you to visit our website (www.audiofocus.eu) to discover the different items that are available.

- Flight cases
- Transport cover with and without grids.
- Hanging systems, brackets, wall stands, coupling tubes
- Audio connectors and cables.

CAUTIONS!

Keep this device away from rain and moisture!

Every person involved with the installation, operation and maintenance of this device has to:

- be qualified.
- follow the instructions of this manual.
- consider this manual to be part of the total product.
- keep this manual for the entire service life of the product.
- pass this manual on to every further owner or user of the product.
- download the latest version of the user manual from the Internet.

Safety instructions:

That device has been CE approved. All the subsets are fully RoHS and CEM compatible.

This speaker-system has left our premises in absolutely perfect condition. In order to maintain this condition and to ensure a safe operation, it is absolutely necessary for the user to follow the safety instructions and warning notes written in this user manual.

Important:

Damages caused by the disregard of this user manual are not subject to warranty. The dealer will not accept liability for any resulting defects or problems.

Please make sure that there are no obvious transport damages. Should you notice any damages on the connection panel or on the casing? Do not take the speaker-system into operation and immediately consult your local dealer.

DANGER OF BURNING!

The materials used in this speaker-system are normally flammable. If B1 is required at the installation place, the surface must be treated with an appropriate fire retardant in regular intervals.

DANGER TO LIFE!

A crashing speaker-system can cause deadly accidents. All safety instructions given in this manual must be observed.

Before the speaker-system is switched on all faders and volume controls have to be set to "-∞" or "min" position.

CAUTION: Turn the amplifier on last and off first!

HEALTH HAZARD!

By operating speaker-systems with an amplifier, you can produce excessive sound pressure levels that may lead to permanent hearing loss. Keep away children and amateurs!

There are no serviceable parts inside the speaker-system. Maintenance and service operations are only to be carried out by authorized dealers.

Operating determinations:

This audio system is a passive or active system which can be used for permanent installations or for mobile use.

This product is only allowed to be connected with appropriate power amplifier and sources. It was designed for indoor use only.

The maximum power of the speaker system must never be exceeded. When operating the speaker system, please make sure that the loudspeakers always sound well. When distortions can be heard, the amplifier or the loudspeaker is overloaded, or signal is very poor quality. Overloads can quickly lead to amplifier, speaker or hears damage.

In order to avoid damage, please reduce the volume immediately when distortions can be heard. When speaker systems are destroyed by overload, the guarantee becomes void.

By operating speaker systems with an amplifier, you can produce excessive sound pressure levels that may lead to permanent hearing loss. Please refer to the explanations under "Legal instructions".

WARNING!

Speaker systems must only be operated by trained persons.

Danger of Life due to crashing speaker systems or hearing loss due to excessive sound pressure levels! The different local conditions have to be considered in terms of safety rules.

When using smoke machines, make sure that the speaker system is never exposed to the direct smoke jet and is installed in a distance of 0.5 meters between smoke machine and speaker system.

The ambient temperature must always be between +3° C and +45° C. Keep away from direct insulation (particularly in cars) and heaters.

This speaker system must only be installed at a solid, plane, anti-slip, vibration-free, oscillation-free and fire-resistant location.

Please note: when using this speaker system in public or industrial areas, a series of safety instructions have to be followed that this manual can only give in part. The operator must therefore inform himself on the current safety instructions and consider them.

Before installing the system, make sure that the installation area can hold a minimum point load of 8 times the system's load (e.g. weight 20 kg - point load 160 kg).

The speaker system must never be installed higher than 100 cm without secondary attachment.

For overhead use (mounting height >100 cm), always fix the speaker system with an appropriate safety rope.

DANGER!

This speaker system must only be suspended by experienced and trained persons - Danger to Life due to crashing speaker systems!

If the original speaker system is equipped with an appropriate flange, this speaker system can be installed on top of a subwoofer (satellite system), on a speaker stand, an appropriate stand or an appropriate wall-mounting. The carrying capacity of the distance-tube, the speaker stand, the stand or the wall-mounting must never be exceeded.

The Top units must always provide enough stability. The Sub unit base surface must always be sufficiently dimensioned in relation to the top speaker in order to prevent tilting over.

Operate the speaker system only after having familiarized with its functions. Do not permit operation by persons not qualified for operating the speaker system. Most damages are the result of unprofessional operation!

Speaker systems must never be transported with cranes. Never stack heavy objects on this speaker system. Persons must never climb onto this speaker system.

Never use solvents or aggressive detergents in order to clean the speaker system! Rather use a soft and damp cloth.

Please consider that unauthorized modifications on the speaker system are forbidden due to safety reasons!

If this speaker system will be operated in any way different to the one described in this manual, the product may suffer damages and the guarantee becomes void. Furthermore, any other operation may lead to dangers like crashes, hearing loss etc.



LEGAL INSTRUCTIONS:

Operating an amplification system can produce extremely high noise levels that may cause a permanent hearing loss. The legal instructions for using an amplification system vary from country to country. The user must always inform himself on the legal instructions valid in his country and apply them to his situation. Always monitor the sound pressure level when operating an amplification system in discotheques, concerts etc. Never exceed the permissible noise level exposures as specified by your authorities. The monitoring of the noise levels must be documented in an appropriate way.

Hearing damage caused by high noise levels can be treated as physical injury and persecuted by law. Please note that the organizer is responsible for keeping to a specified noise level. If this noise level will be exceeded, the event may be cancelled immediately.

If the organizer does not fulfil his safety duties, he is liable by civil law for any damages occurred, e.g.: Pay the treatment costs of the damaged person, pay a smart money to the damaged person.

Economic damage caused can be demanded from the operator of the amplification system. If hired persons work with amplification systems: the noise levels of music events are almost always too high. This is why the entrepreneur has to set up warning signs and provide hearing protectors. The staff has to use these.



AudioFocus© cannot be made liable for damages caused by incorrect installations and excessive noise levels.

AUDIOFOCUS



When music meets science and technology

AudioFocus© contacts :

Web site : www.audiofocus.eu

General *contact* : sales@audiofocus.eu

Phone : +32-83.21.80.54

Fax : +32-83.21.80.57